

Guardian 1.0

Vektek's Machine Tool Protector



INSTRUCTIONAL VIDEOS



VEKTEK, LLC
1334 East Sixth Avenue
Emporia, KS 66801
1-800-992-0236
www.vektek.com

SIMPLE SYSTEM
33-0111-10



PL-3305 REV. E IAW ECN-5712

PAGE 1 of 34



Current Guardian 1.0 Simple Manual

Safety

Read and follow the safety guidelines in the Vektek Inch Hydraulic Catalog before proceeding. Be sure **TO ALWAYS DISCONNECT POWER AND DISCHARGE HYDRAULIC PRESSURE** before **ANY** service work is done. Be sure to practice **LOCKOUT-TAGOUT** procedures on power sources both electronic and hydraulic.

Vektek, LLC reserves the right to change specifications without notice as a part of our ongoing product improvement process

Copyright 2010 – 2024, Vektek LLC, All Rights Reserved

Vektek, LLC
1334 East Sixth Avenue
Emporia, KS 66801
1-800-992-0236
sales@vektek.com
www.vektek.com

PL3305 Rev. E IAW ECN-5712

Guardian Simple Contents:

Table of Contents

Safety	2
Overview	5
Guardian Pre-installation Checklist (what to know before your start)	5
Installing the Fixture Transmitter	6
Mounting Considerations	6
<i>Setting the pressure switch Using a 33-0110-15 Pressure Setter</i>	8
Installing the Machine Tool Receiver	9
<i>Mounting Instructions</i>	9
<i>MASTER CONTROL UNIT Installation</i>	13
<i>Simple Master Control Unit Wiring</i>	14
<i>Powering the Master Control Unit</i>	14
<i>Outputs</i>	15
<i>Using the Master Control Unit</i>	16
<i>Condition Relay Output (Simple Model)</i>	16
<i>Run Mode Screen</i>	17
<i>Guardian Simple System Menu Adjustments:</i>	19
<i>Signal Logic and Actions Taken</i>	24
Maintenance	24
Specifications	25
Guardian Accessory Parts and Dimensions	26
Troubleshooting	27
Quick Start Users Guide	28
<i>What's in the package?</i>	28
<i>How to hook it up (wiring only):</i>	28
System Setup	29
Appendix A – Example Machine M-Code hookup schematic	30
Manual Supplement	31
<i>RS-232 Serial Interface</i>	31

Table of Figures

Figure 1: Best Fixture Transmitter Placement	6
Figure 2: Fixture Transmitter 33-0111-03 -04 and -05 mounting dimensions	6
Figure 3: Pressure Switch Options	7
Figure 4: Pressure Switch Setter Checker	8
Figure 5: Guardian Simple monitoring outside	9
Figure 6: Guardian Simple monitoring inside	10
Figure 7: Machine Tool Receiver Mounting Considerations	11
Figure 8: Machine Tool Receiver 33-0111-02 with Mounting Bracket Dimensions	12
Figure 9: Direction Label Machine Tool Receiver	12
Figure 10: Master Control Unit mounting dimensions	13
Figure 11: Master Control Unit Wiring	14
Figure 12: Master Control Unit Power Connection	14
Figure 13: Master Control Unit Output Relay	15
Figure 14: Master Control Unit Wiring Pictorial	15
Figure 15: Jumper Settings, Defaulted to Outermost Pins (33-0110-14)	16
Figure 16: Run Mode Screen Simple System (Pressure Good)	17
Figure 17: Condition Relay Status (No Pressure)	17
Figure 18: Pallet ID and Status (no pallet)	18
Figure 19: Simple Model Run Mode Screens	18
Figure 20: Configuration Menu and Settings	19
Figure 21: Diagnostics	19
Figure 22: Machine Tool Receiver Power Level	20
Figure 23: RSSI Floor	20
Figure 24: FTU Time Out	21
Figure 25: FTU Mode	21
Figure 26: Firmware Version	22
Figure 27: Pallet Serial	23
Figure 28: Guardian Specifications	25
Figure 29: Guardian Simple Troubleshooting	27
Figure 30: Guardian Simple interface wiring only	28
Figure 31: Guardian Boot Screen	29
Figure 32: Guardian Simple (33-0110-14) Main Screen	29
Figure 33: Wiring schematic for the Guardian Simple system that is integrated into the load stations cycle in push button	30
Figure 34: Pallet Serial	32
Figure 35 - Serial Port Pin Out	33

Overview

The Guardian 1.0™ is a wireless pressure monitoring system designed to communicate pressure feedback from hydraulic workholding fixtures to a CNC machine controller. The Guardian 1.0™ System consists of three pieces, the MASTER CONTROL UNIT, MACHINE TOOL RECEIVER and the FIXTURE TRANSMITTER.

The FIXTURE TRANSMITTER UNIT is a sealed (IP67 rated), compact, low power device that does not require batteries. The FIXTURE TRANSMITTER UNIT is powered by Focused Field communication with the MACHINE TOOL RECEIVER. This Focused Field communication allows the FIXTURE TRANSMITTER UNIT to be battery free and quickly identified by the MACHINE TOOL RECEIVER. The FIXTURE TRANSMITTER UNIT accepts an input from a non-powered/dry contact sensing switch via an M8 IP67 shielded cable and continuously reports the status of this switch over a radio link. Vektek recommends pressure switch, P/N 70-7500-78, for hydraulic pressure monitoring. This makes the FIXTURE TRANSMITTER UNIT a virtually maintenance free part of your Guardian 1.0 system.

The MACHINE TOOL RECEIVER is the communication gateway communicating with both the FIXTURE TRANSMITTER UNIT and the MASTER CONTROL UNIT. The MACHINE TOOL RECEIVER connects to the MASTER CONTROL UNIT via an M12 cable. The M12 IP67 shielded cable carries information from the MACHINE TOOL RECEIVER to the MASTER CONTROL UNIT. The MACHINE TOOL RECEIVER connects to the FIXTURE TRANSMITTER UNIT wirelessly. The MACHINE TOOL RECEIVER is a fully sealed unit (IP67 rated) that can mount within the machine enclosure or external to the enclosure to communicate with the FIXTURE TRANSMITTER UNIT as well as isolate communication to only the FIXTURE TRANSMITTER UNIT located within the Focused Field.

The MASTER CONTROL UNIT is the hub of the Guardian System. It receives the fixture's information and pallet pressure, and both displays it via an LCD to the operator and transmits it to an external machine controller or PLC (Programmable Logic Controller).

Guardian Pre-installation Checklist *(what to know before your start)*

- What should happen if low pressure is detected?
- Where are the In-Cycle, Feed-Hold or E-Stop terminals on the machine tool, are they open or will the Guardian need to tie into currently dedicated In-Cycle, E-Stop, or Feed Hold wiring?
- Where are the M-Code terminals on the machine, and are there any available (if using)?
- Is the machine positive or negative case ground (which is switched on/off)?
- Where should the Guardian Master Control Unit be located?
- Should the Guardian Machine Tool Receiver be mounted inside or outside the machine enclosure?
- What length of cable is going to be necessary to connect the Machine Tool Receiver to the Master Control Unit, ≤ 32.8 feet?
- Where will the Master Control Unit get power?
- Where will the Guardian Fixture Transmitters be mounted to your pallet?
- What is the critical pressure at which the machine needs to stop?
- Will you need help from the Machine Tool Distributor's service staff or does your staff have the knowledge and ability to install the Guardian?

Installing the Fixture Transmitter

Mounting Considerations

The Fixture Transmitter Unit should be mounted in a secure location out of paths of interference for line of sight communication to the Machine Tool Receiver. Due to the ability of the Guardian to identify the Fixture Transmitter under interrogation, the units should be mounted to provide the best possible clear path of communication and within 6 feet of the Machine Tool Receiver. The figure below shows both good and bad examples of three transmitters in different positions; however, only one Fixture Transmitter per fixture is allowed but a single transmitter can monitor 1 to 4 pressure switches. Note: Shielding is not necessary or allowed. The transmitter is IP 67 rated and any metal shielding will interfere with communication.

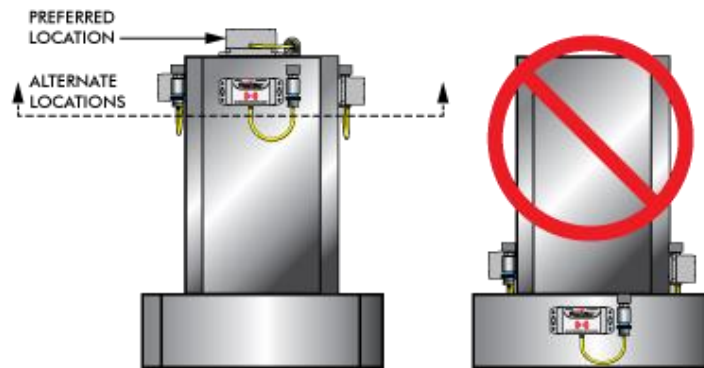

Figure 1: Best Fixture Transmitter Placement

Step 1: Mount the transmitter using two ¼” or 6mm bolts oriented so the M8 connector is readily accessible to connect the pressure switch cable. For proper operation, The Fixture transmitter will need to be elevated from the surface of the fixture use a single washer under each tab. Below are mounting dimensions for the Fixture Transmitter available with 1, 2 (-04) or 4 (-05) pressure switch connectors.

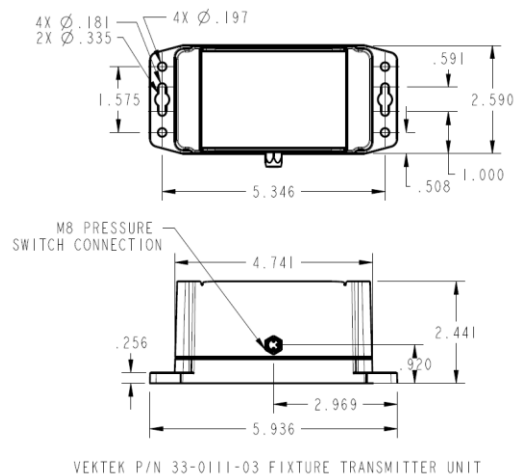
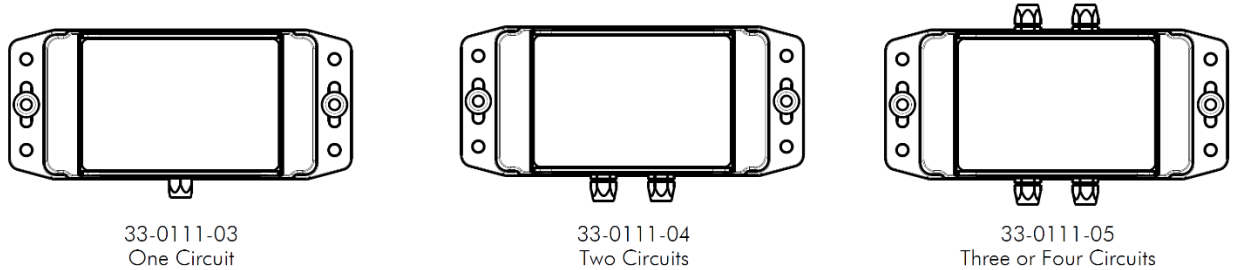

Figure 2: Fixture Transmitter 33-0111-03 -04 and -05 mounting dimensions

Vektek Guardian™ Simple Model User's Guide

Fixture Transmitters



GUARDIAN FIXTURE TRANSMITTER ACCESSORIES	
70-7500-78	750-5000PSI PRESSURE SWITCH WITH 19.7 IN CABLE (SHOWN)
70-7500-74*	750-5000PSI PRESSURE SWITCH WITH M8 MALE CONNECTION ONLY
27-7424-01	M8 SHIELDED PATCH CABLE (MALE TO FEMALE) FOR USER PROVIDED NON-POWERED SWITCH OR REPLACEMENT FOR 70-7500-78

*70-7500-74- REQUIRES USER PROVIDED 3 PIN M8 SHIELDED CABLE

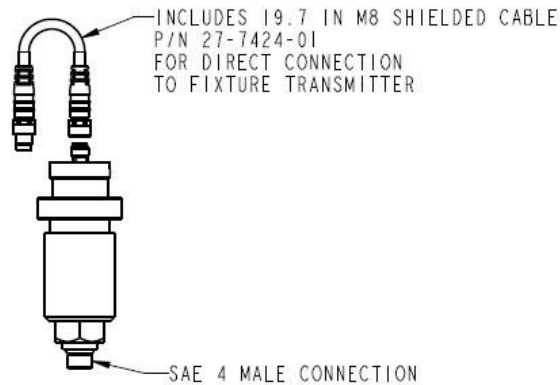

ORDER VEKTEK PRESSURE SWITCH P/N 70-7500-78
FOR DIRECT CONNECTION TO FIXTURE TRANSMITTER

Figure 3: Pressure Switch Options

Step 2: Connect the pressure switch cable to the transmitter.

Step 3: Set pressure switch to the minimum desired pressure, using the instructions below.

Transmitter Wiring Options: We recommend using a Vektek 70-7500-78 unpowered mechanical pressure switch. An appropriate quantity is enclosed with each Guardian package. Other sealed, unpowered mechanical Normally Open pressure switches may be used. They must have shielded cables and be M8 connection, rated IP67 or better. The coolant often used in machining operations may enter non-water-tight switches and cause switch malfunctions. **Use alternate pressure switches at your own risk.**

One option to test your Fixture Transmitter and want to show pressure good, you can use the optional jumper 27-5222-04. This will cause the fixture transmitter to always show pressure good.

This jumper is also for use as a switch “eliminator” on the 33-0111-05 in the case where you want to monitor 3 pressure switches using the 4 port fixture transmitter.

Setting the pressure switch Using a 33-0110-15 Pressure Setter

The purpose of the 33-0110-15 Pressure Switch Setter/Checker is to assist in the setting of the Vektek mechanical pressure switch set point. It allows instant feedback of the pressure switches NO contacts and if they are open or closed at a specific set point.



Figure 4: Pressure Switch Setter Checker

1. Make sure you have good batteries in the Pressure Switch Setter/Checker. (Depending on the model it will be 2-AAA or 1-9V battery.)
2. Connect the attached cable to the Vektek Mechanical Pressure switch connector.
3. Apply the amount of hydraulic pressure you want the pressure switch to activate at. We recommend 250-400 psi below your fixture/pump operational pressure. The exact pressure will need to be determined by the fixture designer. You want the pressure switch to open its contacts before enough pressure is lost to damage a part, let it shift, or come out of its fixture. If the pressure is set to close to the full operational pressure of the fixture, then there could be false alarms caused by normal pressure fluctuations in the system.
4. Turn the adjustment ring of the pressure switch until the LED light is NOT illuminated. (clockwise)
5. Then turn the pressure setting ring back up (counterclockwise) until the LED light is illuminating.
6. Now turn the adjustment ring of the pressure switch until the LED light is NOT illuminated. (clockwise)
7. You now have set the pressure switch at a point so that when the pressure drops below the critical set point the switch opens.

WARNING: It is the customer's responsibility to determine the minimum safe operating pressure for the system. Please test your system to ensure proper switch set pressure.

Installing the Machine Tool Receiver

Mounting Instructions

The Machine Tool Receiver for on a "Simple System" should typically be mounted outside the machining enclosure. If it is installed inside the machine, ensure it is within unobstructed line of sight to the fixture. Possible obstructions may be caused by machine operation, spindle park location, or being directly subjected to high pressure coolant spray. The door brace looking outward is a great place for pressure verification prior to indexing the next pallet into the machine. For the best performance, the Machine Tool Receiver should be within 6 feet of the Fixture transmitter at all times and maintain line of sight. While monitoring inside the machine line of sight to multiple fixtures should be avoided. Mounting the Machine Tool Receiver above the door looking inward is often the best place to give the best view and look away from the inactive pallet. See the illustrations below.

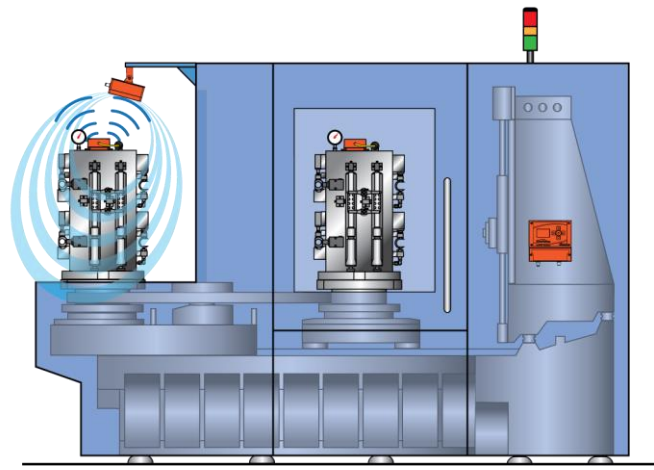

Figure 5: Guardian Simple monitoring outside

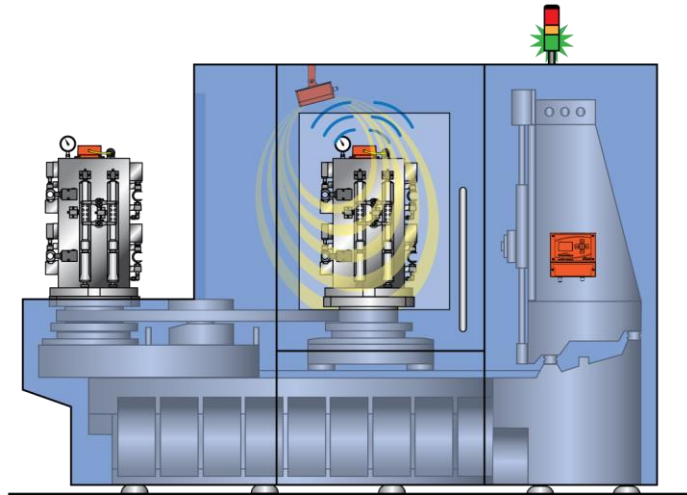

Figure 6: Guardian Simple monitoring inside

The lines in the figure below show the communication path of the Machine Tool Receiver. If the face of the fixture is “visible” to the Machine Tool Receiver a Fixture Transmitter will be “seen” and monitored. Otherwise, if the Fixture Transmitter is on a face opposite the Machine Tool Receiver, the Fixture transmitter will be “shadowed” by the fixture and not effectively monitored. Only 1 transmitter may be used on a fixture. If multiple pressure switches need to be used on a multi sided fixture, select the appropriate Fixture Transmitter with multiple inputs.

Step 1: Use the bracket provided or direct mount the Machine Tool Receiver. The mounting dimensions are on the next page. The MTR is provided with two disc magnets mounted to the bracket that can be used for direct mounting or removed for bolt mounting.

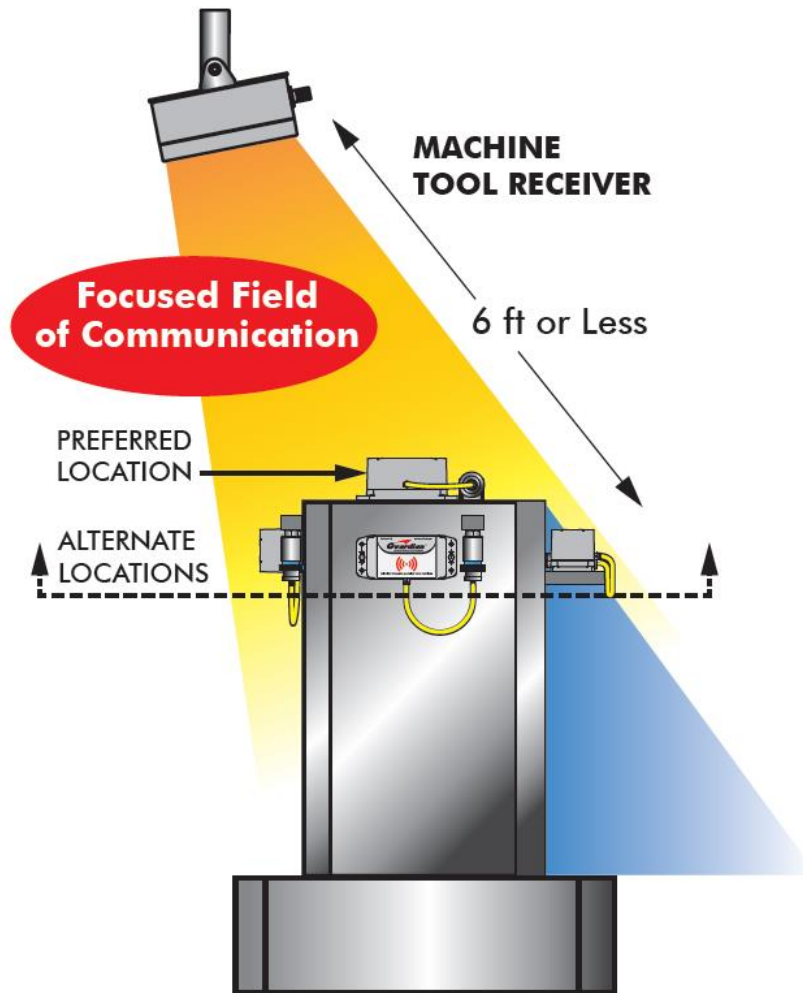

Figure 7: Machine Tool Receiver Mounting Considerations

Note: The label on the front of the Machine Tool Receiver should face the monitor area where the Fixture Transmitter will be located. The Focused Field of Communication is broadcast from the face of the Machine Tool Receiver in the direction of the label.

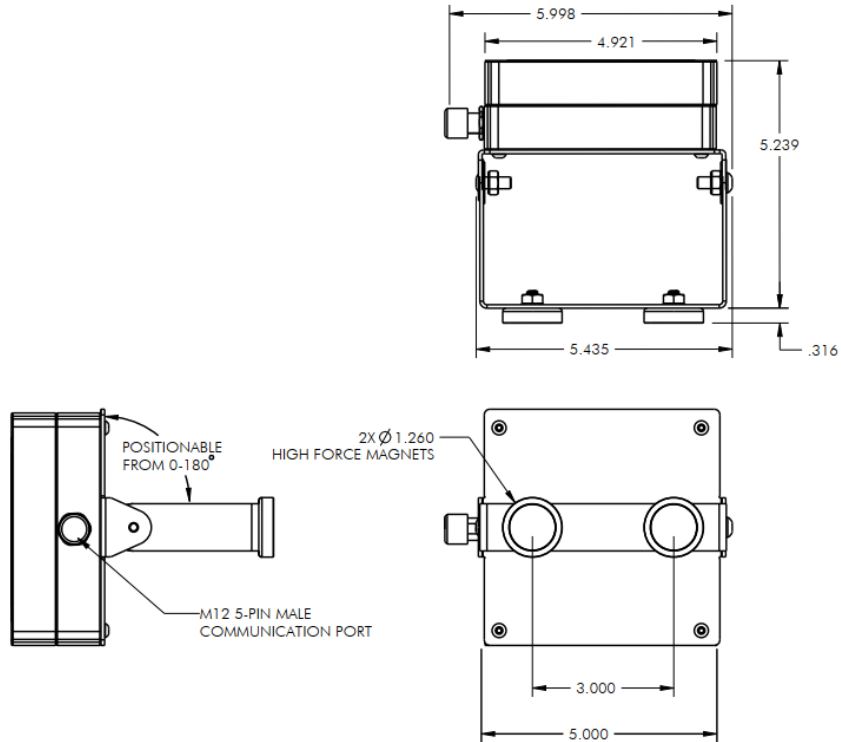

Figure 8: Machine Tool Receiver 33-0111-02 with Mounting Bracket Dimensions

Step 2: With the Machine Tool Receiver mounted, connect the female end of the shielded 5 Pin M12 communication cable to the Machine Tool Receiver. **IMPORTANT: Ensure the side of the Machine Tool Receiver with the Decal in Figure 9 is pointed toward the location of the Fixture transmitter during monitoring.**



Figure 9: Direction Label Machine Tool Receiver

Step 3: Route the 5 Pin M12 communication cable to the Master Control unit. Plug the Male M12 Connector into the M12 communication port on the Master Control Unit. Any excess cable can be coiled and hidden somewhere along the cable route.

Note: The communication cable should be routed to prevent contact with moving parts and sharp edges. Also avoiding contact with machine wiring will ensure maximum performance of the system.

MASTER CONTROL UNIT Installation

Step 1: Mount the Master Control Unit to the CNC machine in a location easily viewed by the operator. Following are dimensions for the mounting holes and possible mounting options on Figure 10 (Not to scale). The Master Control Unit can also be mounted via a 35mm DIN rail (included)

CAUTION!

NOTE: The MASTER CONTROL UNIT is a sealed unit rated IP65 rated, not designed to be mounted within the wet machine environment.

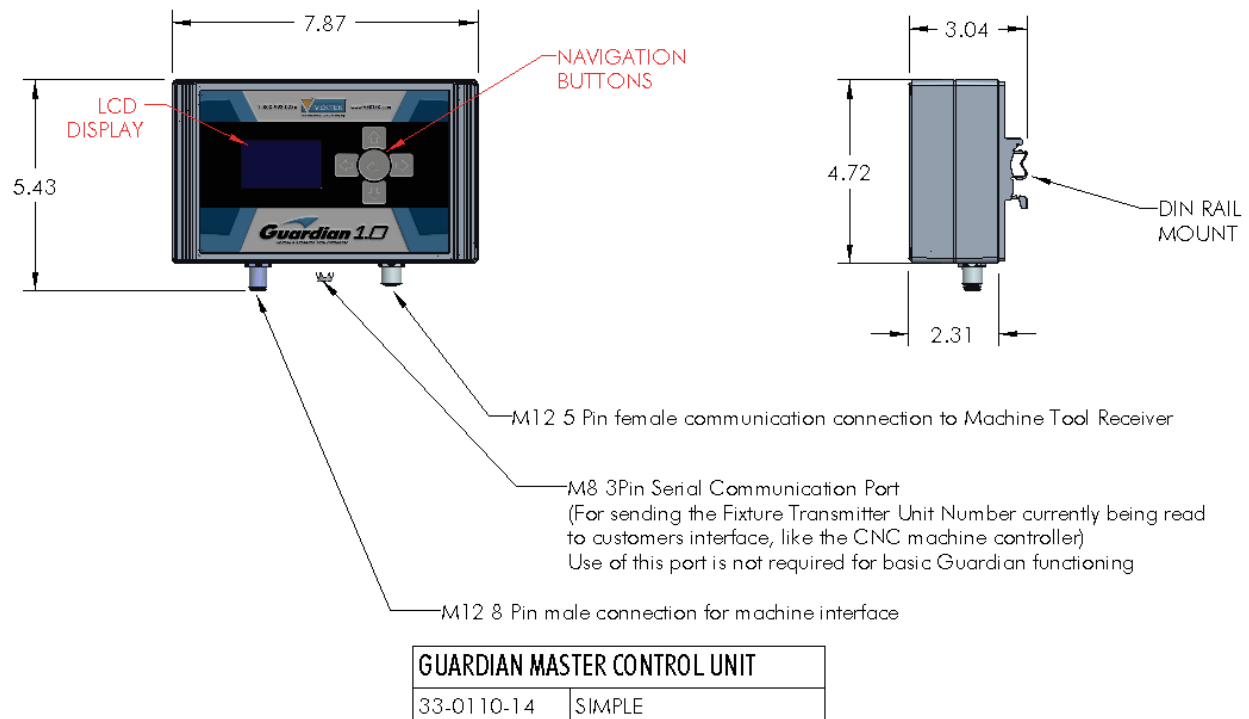

Figure 10: Master Control Unit mounting dimensions

Step 2: Connect the 8 pin M12 cable to the Master Control Unit. Route the cable to machine tool controls electrical enclosure. Find an entrance to the enclosure and determine the longest wire needed. Cut the cable to length, and discard excess cable. Remove cable outer insulation as needed.

Step 3: Unplug the Master Control Unit before continuing.

Step 4: Connect power as instructed in Figures 10 and 11.

Step 5: See the Basic Master Control Unit Wiring (Figure 10) to complete installation.

Simple Master Control Unit Wiring

This section will cover the basic information needed to hook up the Master Control Unit. Below is the wiring chart for the Master Control Unit. The implemented pins for each Model is described below.

Read and understand this section fully before attempting to wire the Guardian™ Master Control Unit. If any of the wiring information remains unclear after reading this section, please contact Vekttek Customer Support at 1-800-992-0236 for additional assistance.

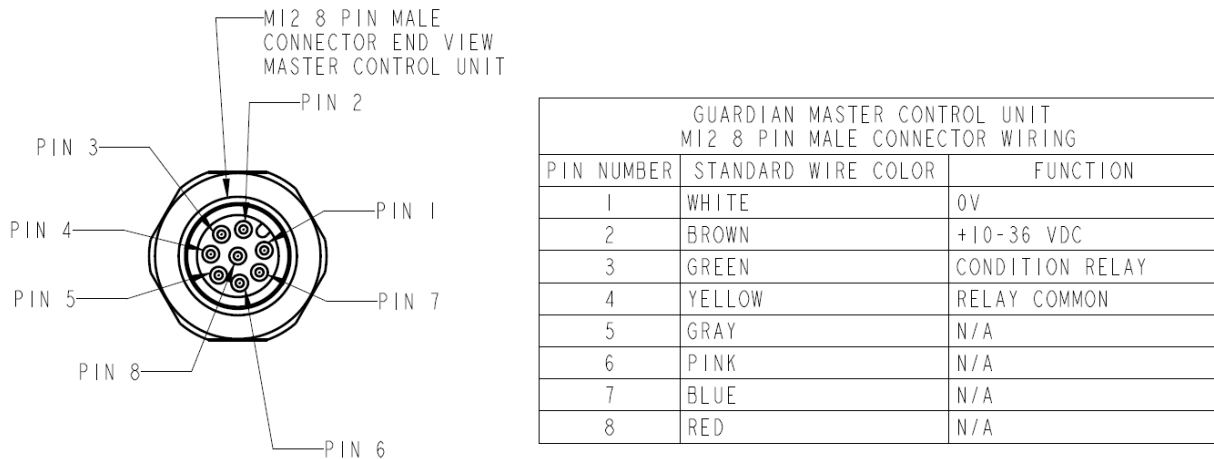

Guardian Master Control Unit
P/N 33-0110-14
M12 8 Pin Male Connector Pinout

Figure 11: Master Control Unit Wiring

Powering the Master Control Unit

There are 2 wires needed to power the unit. These are illustrated below.

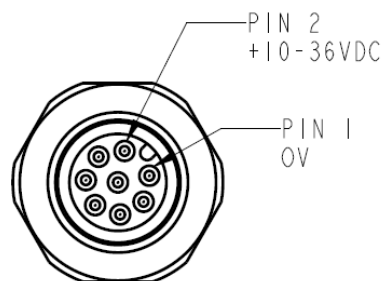

Figure 12: Master Control Unit Power Connection

1. Connect Pin 2 (Brown) to +10-36VDC.
2. Connect Pin 1 (White) to 0 Volts:

Outputs

The output of the Master Control Unit is a dry contact relay. It toggles in relation to the switch being monitored through the Fixture Transmitter and Machine Tool Receiver.

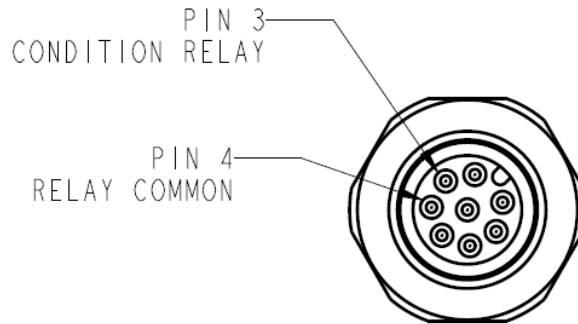

Figure 13: Master Control Unit Output Relay

Machine Inputs Requiring 24V:

- Connect the Guardian Output Pin 3 (GREEN) to selected machine input.
- Connect Pin 4 (YELLOW) to +DC source of the control.

Machine Inputs Requiring 0 Volts:

- Connect the Guardian Output Pin 3 (GREEN) to Machine Inputs
- Connect Pin 4 (YELLOW) to 0 Volts

NOTE: It is the user's responsibility to connect the output to the appropriate circuit for machine protection. It is also the responsibility of the user to determine the monitoring frequency, method and appropriate action based on expertise and availability of functions within the controller and software available on user's machine. (Typical actions; Do not Index, Feed Hold or E-Stop.)

SIMPLE SYSTEM WIRING

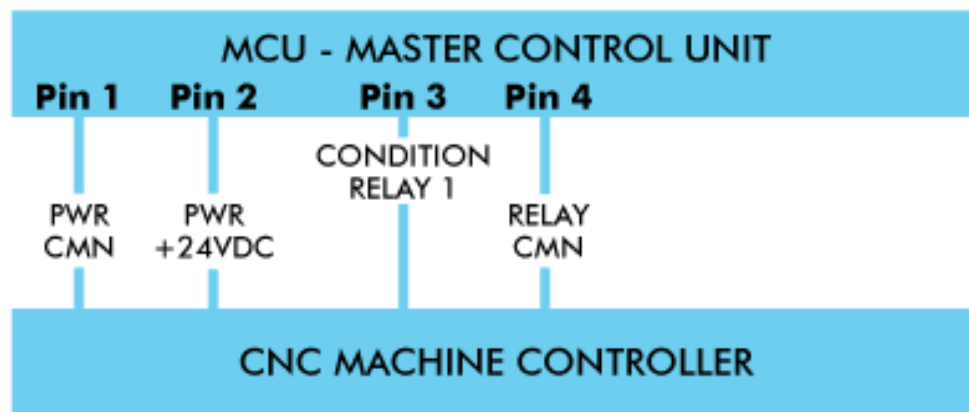

Figure 14: Master Control Unit Wiring Pictorial

Using the Master Control Unit

Condition Relay Output (Simple Model)

The Condition Relay is used to communicate the status of the pressure switch to the machine tool or other device. With the Simple System, the Condition Relay will follow the status of any Fixture Transmitter pressure switch within the Focused Field of Communication. At any time the Fixture Transmitter sees a pressure switch state change the Simple System will immediately communicate the change via the condition relay. The default condition as shipped from the factory is Relay Normally Open (closed when positive pressure and signal are confirmed), this can be adjusted to be Normally Closed by changing jumper as illustrated below. For simplicity this manual is written assuming Relay Normally Open and if the jumper is reset as on the right hand illustration, the user must understand that the logic is reversed.

The Guardian comes with the relay jumper in the Normally Open position. (two outermost pins are jumpered) you can move the jumper to the two innermost pins to change the relay to the Normally Closed position.

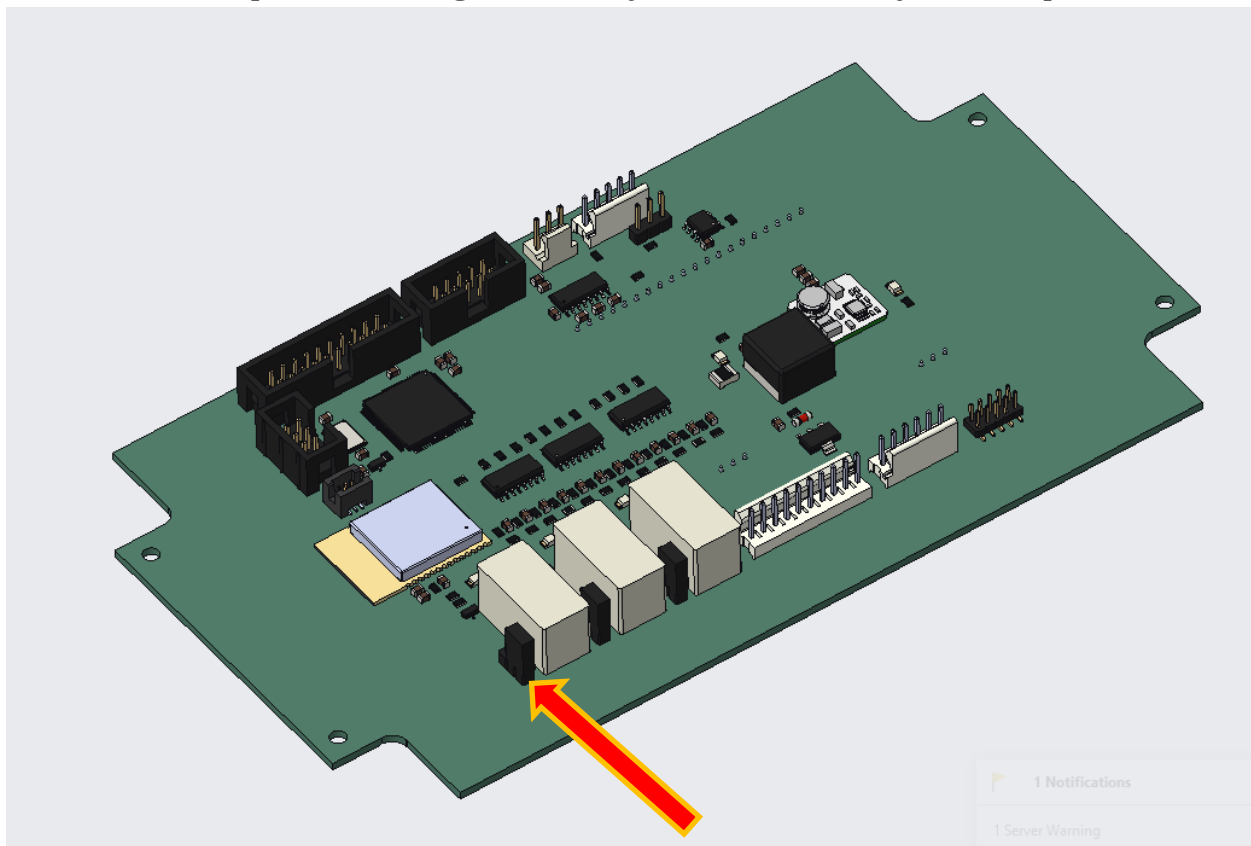

Figure 15: Jumper Settings, Defaulted to Outermost Pins (33-0110-14)

Run Mode Screen

When the Master Control Unit is powered and operating properly the following screen will be present. If this screen is not present, use the ↓↑ keys to undo any selections and hit <ENTER>. If the screen does not display RUN MODE, **Contact Vekttek Customer support at 1-800-992-0236 for additional assistance.**



Figure 16: Run Mode Screen Simple System (Pressure Good)

The Simple System shows information about the pallet currently in communication and the condition of the relay (CONFIRMED or FAULT).



Figure 17: Condition Relay Status (No Pressure)

The Condition Relay status is shown above. The Status of the Condition Relay will either be Confirmed or Fault depending on the jumper setting and status of the Fixture Transmitter within the Focused Field of Communication. If there is no Fixture Transmitter present the Condition Relay will default to the Fault and no pallet id will be displayed. There are only 2 values for the Condition Relay:

- CONFIRMED- The Condition Relay is made (Output ON). The CONFIRMED Position indicates that a Fixture Transmitter is within Range and its pressure switch is at or above its set pressure.
- FAULT- The Condition Relay is broken (Output OFF). The FAULT Position can indicate 2 distinct states.
 - State 1- No Fixture Transmitter Present. There are no Fixture transmitters within the Focused Field of Communication. Confirm this state by comparing the Pallet ID

status shown in Figures 17 and 18 with good reception and Figure 18 with no FTU reception.

- State 2- A Fixture Transmitter is present and the Pressure switch is below its setpoint (pressure loss). Again, this can be confirmed using the Pallet Id and Status at the bottom of the screen.



Figure 18: Pallet ID and Status (no pallet)

The Figures 17 and 18 show the display of the Pallet ID and Status. When a Fixture Transmitter is within the Focused Field of Communication, the Pallet ID will display the last 2-4 digits of the Unique ID of the Fixture Transmitter. If no Fixture Transmitter is available, the display will be like Figure 17. There are 3 statuses available for the Fixture Transmitter being monitored. They are as follows:

- PRS GOOD- The pressure switch is at or above the set point. If a customer provided switch is used this would show that the switch is closed (Normally Open switch type must be used)
- NO PRS- The pressure switch is below the reset point or a pressure. If a customer provided switch is used, this would show that the switch is open (Normally Open Switch Type must be used)
- NO PALLET- No pallet fixture transmitter is within the Focused Field.



Figure 19: Simple Model Run Mode Screens

NOTE: The Simple Units do not use the Pallet ID input for any purpose other than identification of communication and visual display. Simple systems use no inputs.

In Figure 19, the display shows the marching dots (+ + +) indicate active communication between the controller and the Machine Tool Receiver. Each dot represents the successful receipt of a data packet transmitted by the FTU. As packets are received in sequence, the dots move across the screen to provide a visual confirmation that data exchange is continuous and healthy. If the dots stop progressing or disappear, it suggests that packet transmission has stalled or communication with the Machine Tool Receiver has been lost. This simple visual indicator allows operators to quickly verify link status without the need for additional diagnostic tools.

Guardian Simple System Menu Adjustments:



Figure 20: Configuration Menu and Settings

Hold the ENTER button for 4 seconds to access the configuration menu.

In the Simple System, there is a Diagnostics menu to verify the I/O and 5 Settings and 1 Information menu selection:

The Diagnostics Menu shows status of the Inputs and allows the relay outputs to be energized.

Diagnostics – To verify wiring and I/O function, you can use the diagnostics menu to check the state of the Inputs(not used in the Simple System) and you can turn the Output Relays on one at a time.

The Output 0 relay is the Pressure Confirmation relay that should be connected to the machining system. Move the cursor over the line for the outputs using the Up/Down arrows on the keypad. Once on the line, every time you press the Enter key, the outputs will cycle on and off. Relays 1 and 2 are not supported in the Guardian Simple System and are for future features.



Figure 21: Diagnostics

The Setting Menu items are:

- MTR Power
- RSSI Floor
- FTU Tout
- FTU Mode
- Pallet Serial

The Information screen is to show the MCU and MTR firmware versions.

- FW Versions



Figure 22: Machine Tool Receiver Power Level

MTR Power - This is the output power from the Machine Tool Receiver to power the Fixture Transmitter and the range is from 15 to 30, it has a factory default setting of 26. This is a typical power setting and should be lowered to prevent cross talk from multiple Fixture Transmitters or increased for larger machining areas.

Example: A pallet is in the load station and the machining area and the Guardian system bounces back and forth between the two pallets. Lower the setting to reduce cross talk.

- To set the MTR Power, hold the enter button for 4 seconds. This accesses the diagnostics menu.
- Use the down arrow to scroll to settings. Press enter.
- Scroll to MTR Power. Press Enter
- Change value to something within the parameters*



Figure 23: RSSI Floor

RSSI Floor – The factory default setting for this parameter is 40. The RSSI Floor setting is used by the FTU interrogation algorithm to determine which Fixture Transmitters to ignore if multiple FTU respond to communication requests from the MTR. This can help in the situation where two pallets are close together in the pallet changer and the system can't determine which FTU to pay attention too. The lower the number the weaker the signal, the higher the number the stronger the signal.

- To set the RSSI Floor, hold the enter button for 4 seconds. This accesses the diagnostics menu.
- Use the down arrow to scroll to settings. Press enter.
- Scroll to RSSI Floor. Press Enter
- Change value to something within the parameters*

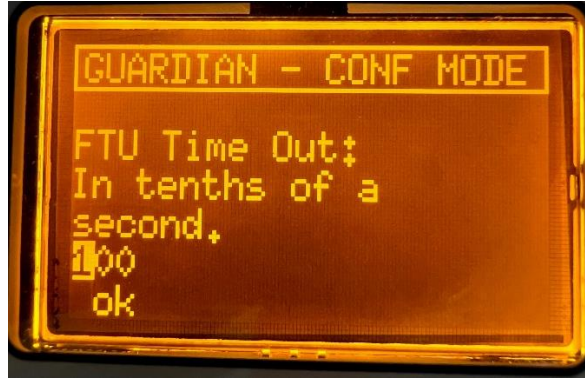

Figure 24: FTU Time Out

FTU Tout – The factory default setting for this parameter is 10.0. This setting is the allowable amount of time that communication can be lost before it faults. This has units based in tenths of a second. The timer resets after communication is reestablished with the Fixture Transmitter.

- To set the FTU Tout, hold the enter button for 4 seconds. This accesses the diagnostics menu.
- Use the down arrow to scroll to settings. Press Enter.
- Scroll to FTU Tout. Press Enter
- Change value to something within the parameters*



Figure 25: FTU Mode

FTU Mode – The factory default setting for this parameter is 3. This setting selects which internal FTU selection algorithm is used by the MCU to determine which FTU should be monitored for pressure.

Mode 1 – When this is selected, the first FTU that responds to the MTR request will be sent to the MCU and that one will be used as the FTU to monitor pressure. This Mode should not be used in most applications.

Mode 2 – When this is selected, all FTU's reporting to the MTR request will be sent to the MCU. The MCU will use an algorithm to maintain a table that counts how many times in a period of time an FTU responds to the MTR request. The more times an FTU responds in a give period usually means it is

closer to the MTR. Care should be used with this Mode if FTUs are used close together or in a congested area.

Mode 3 – This is the default mode. When this mode is selected the MTR sends the FTU information to the MCU with the FTU who has the highest transmission RF Power level. Typically any FTU that is closer and direct line of site and not a reflection will have the highest RF transmission power. The MCU will use this FTU to monitor pressure.

- To set the FTU Mode, hold the enter button for 4 seconds. This accesses the diagnostics menu.
- Use the down arrow to scroll to Settings. Press Enter.
- Scroll to FTU Mode. Press Enter
- Change value between 1 and 3. If you select something outside those bounds, the nearest valid selection is used.

*** If the value is outside the range, you may have to edit the value, back out of the menu and re-enter to allow adjustment within the range. If you experience any difficulties with configuration, please contact Vektek support at 1-800-992-0126 or +1-913-365-1045.**



Figure 26: Firmware Version

Firmware Versions – The “FW Versions” menu item will show the firmware version in both the MCU and the MTR. There isn’t a firmware version in the FTU, so none will be shown. If no firmware version is displayed for the MTR, there is a communication issue with the MTR. Please check that the cable is connected to the MCU and the MTR properly and then cycle power to the MCU.



Figure 27: Pallet Serial

Pallet Serial – The factory default setting for this parameter is 0. This setting determines how Fixture Transmitter(FTU) serial number information is transmitted on the Optional RS-232 Serial Interface.

Mode 0 – Output is disabled on the serial interface. This is the default mode.

Mode 1 – When this is selected, the last 4 digits of the FTU unique serial number that is being used for pressure monitoring, will be transmitted on the serial interface when ever the FTU has good pressure.

Mode 2 – When this is selected, the last 4 digits of the FTU unique serial number that is being used for pressure monitoring, will be transmitted ever 3-5 seconds.

Mode 3 – When this is selected, the last 4 digits of the FTU unique serial number that is being used for pressure monitoring, will be transmitted when ever the MCU receives a request command from the CNC Machine Controller over the RS-232 Serial Interface RX line.

- To set the Pallet Serial, hold the enter button for 4 seconds. This accesses the diagnostics menu.
- Use the down arrow to scroll to Settings. Press Enter.
- Scroll to Pallet Serial. Press Enter
- Change value between 1 and 3. If you select something outside those bounds, the nearest valid selection is used.

*** If the value is outside the range, you may have to edit the value, back out of the menu and re-enter to allow adjustment within the range. If you experience any difficulties with configuration, please contact Vektek support at 1-800-992-0126 or +1-913-365-1045.**

Signal Logic and Actions Taken

Signal logic is very “Simple” on the Simple Guardian Unit.

- 1) Relay is off or relay is on (continuity or switching a supplied voltage), can be sent to the machine control or wired to switch another function ON or OFF.
- 2) Interrogation modes which confirm Guardian’s relay is either open or closed are programmed into and governed by your Controller, often in the part program or the pallet swap instructions. Examples are in Appendix A at the end of this manual.
- 3) **How do you want to monitor fixture pressure?**
 - a. In typical use, M-Code interrogation outside machine before indexing fixture into the machine prevents indexing an unpressurized fixture into the machine. In this case, the receiver mounted outside the machine enclosure.
 - b. M-code interrogation while machining the signal may be checked by an “M-Code Call” within the program (typically during a tool change). In this case the receiver is mounted inside the machine enclosure.
 - c. Change of state. If your machine tool can sense a change of state (open to closed or closed to open) during the load or cutting time of your operation, it can be monitored in “real time.” Note: Change of state monitoring requires a latched input and must be disabled (unlatched by your machine programming) during pallet indexing to avoid false alarms as the 2 pallets exit and enter the Focused Field.
- 4) **How do you want your machine to react?**
 - a. The output relay must be connected to an M-code which sends a signal to the machine to perform the appropriate User Defined function.
 - i. Do Not Index if monitoring before indexing.
 - ii. Feed hold if monitoring a fixture within the enclosure. OR
 - iii. E-Stop if monitoring a fixture within the enclosure.
- 5) Interrogating the pallet during transportation to the machine on a pallet spooler or rail transport system can pre-verify pressure when pallets are stored at a distance. In this case, please refer to the PLC for appropriate inputs and resulting actions. This is one of the exclusive advantages of the Focused Field Communications only available with Guardian.

Maintenance

The entire Guardian system is designed to be nearly maintenance free. There is a 1.5A fuse to protect the Machine Tool Receiver, all of the units require no periodic maintenance. Vektek does recommend that the face of the Master Control Unit be cleaned periodically with a mild cleaner (i.e. non-ammonia glass cleaner) to remove foreign matter from the screen. The Fixture Transmitter and Machine Tool Receiver should be inspected occasional to check for damage to the enclosures.

Specifications

Guardian Specification Chart			
Master Control Unit P/N 33-0110-14	Power	<i>Negative Case Ground</i>	+10-36 VDC
	Connection	<i>Power & Inputs/Outputs</i>	1x M12 - 8 Pin
		<i>TO MTR</i>	1x M12 - 5 Pin
	Cable	<i>Power & Inputs/Outputs</i>	32.8ft
	Inputs	<i>Number</i>	0
		<i>Type</i>	Sourcing
		<i>Rating</i>	5-36 VDC
	Outputs	<i>Number</i>	1
		<i>Type - Relay Contact</i>	Sourcing/Sinking
		<i>Rating (Total for all outputs)</i>	2 amps
	Machine Tool Receiver P/N 33-0111-02	Power	<i>Negative Case Ground</i>
Frequency			900 MHz
Connection		<i>Power & Inputs/Outputs</i>	1x M12 - 5 Pin
Cable			32.8ft
Fixture Transmitter Capacity			Unlimited
Batteries			Not required
Fixture Transmitter P/N 33-0110-03	Frequency		900MHz
	Input		3 Pin M8

Figure 28: Guardian Specifications

Guardian Accessory Parts and Dimensions

GUARDIAN ACCESSORIES			
Cables			
Model No.	Description	Connection	Length (ft)
27-6424-04	Cable, M12 8 Pin Master Control Unit Machine Tool Interface *	Female Straight - Open End	32.8
27-9422-01	Extension Cable M12 5 Pin Master Control Unit to Machine Tool Receiver Communication Cable **	Female Straight - Male Straight	32.8
27-7422-05			16.4
27-7424-02	Extension Cable M8 3 Pin Shielded Pressure Switch to Fixture Transmitter	Female Straight - Male Straight	3.5
27-7424-01			2.2
27-7424-04			1.2
Pressure Switches			
70-7500-78	750-5000PSI Pressure Switch with 19.7 IN Cable (Shown)		
70-7500-74	750-5000PSI Pressure Switch with M8 Male Connection Only ***		
33-0110-15	Pressure Setter / Checker to assist setting mechanical pressure switches		
Connectors			
27-5222-04	Guardian, M8 3 Pin Jumper, use with 33-0111-03,04,05		

- * Included with 33-0101-10 & 33-0111-10 can be purchase separately for replacement or additional hook up.
- ** 27-9422-01 is included with 33-0101-10 & 33-0111-10.
- Cables can be purchased separately for extension or replacement
- *** 70-7500-74- Requires User Provided 3 Pin M8 Shielded Cable

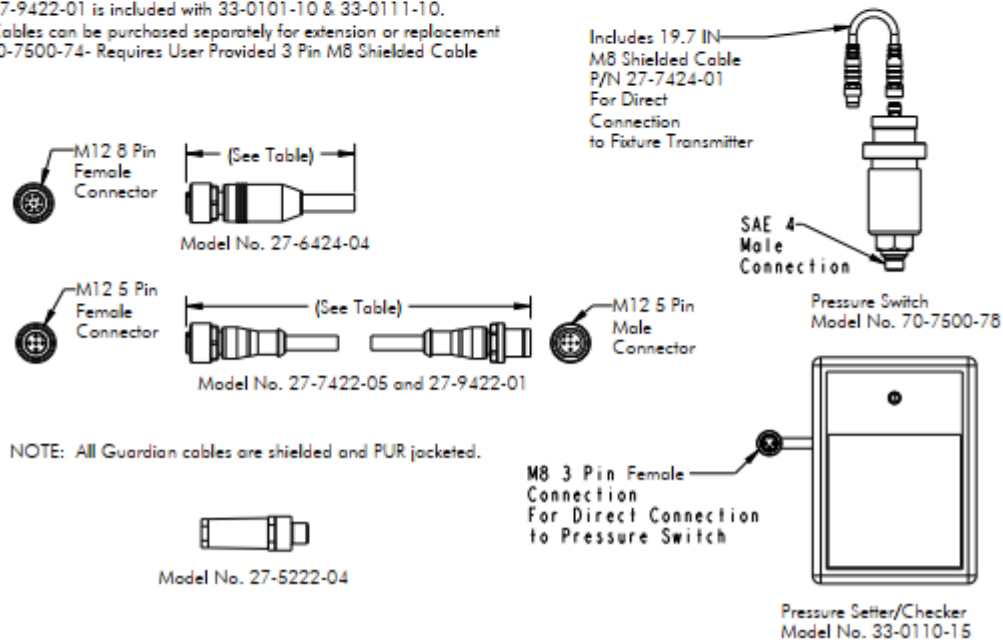

Figure 26: Guardian Accessories

Troubleshooting

Symptom	Cause	Solution
MCU does not power on.	<ol style="list-style-type: none"> 1. No power 2. Bad Ground 	<ol style="list-style-type: none"> 1. Check ground connection 2. Check Fuse 3. Check from Positive pin 2 to pin 1 Ground for +10-36VDC
MCU does not communicate with FIXTURE TRANSMITTER	<ol style="list-style-type: none"> 1. Out of Range (over 6ft) 2. FTU is covered in chips. 3. FTU is damaged 4. MTR is unplugged 5. MTR is damaged 6. MTR is blocked or covered with chips 	<ol style="list-style-type: none"> 1. Move FTU closer 2. Clear chips. 3. Replace FTU. 4. Reattach cable or replace cable. 5. Replace MTR. 6. Clear chips or relocate MTR.
Machine always shows the alarm.	<ol style="list-style-type: none"> 1. FTU reporting no pressure 2. Machine is not using correct logic to interpret Guardian output. 3. Main Contact or jumpers are not wired correctly 4. Logic of Guardian outputs not correct. 	<ol style="list-style-type: none"> 1. Use Pressure Switch Setter/Checker to determine if continuity is present (pressure switch contact is closed). 2. Invert Machine Logic or output jumpers. 3. Check wiring. 4. Use Diagnostics menu to toggle Main Contact and check function of input to machine. 5. Verify that the Guardian relay output is set as expected to either Normally Closed or Normally Open. 6. Check connection of Relay Common. Connect Relay Common to the voltage for the proper signal, 24V for a 24V signal and 0V for a 0V signal.

Figure 29: Guardian Simple Troubleshooting

If the preceding chart does not correct the problem, please contact Vekttek Customer Support at 1-800-992-0236 for additional assistance. Please have MACHINE TOOL RECEIVER version and ID number available for technical support.

Quick Start Users Guide

Congratulations on purchasing the Vekttek Guardian™! The following is a step by step quick start instruction guide to help you get the Guardian™ up and running with ease.

What's in the package?

The Guardian™ Simple system includes: 2 Fixture Transmitters P/N 33-0111-03, Machine Tool Receiver P/N 33-0111-02, Master Control Unit P/N 33-0110-14, Master Control Cable and Communication IP67 rated cables for connection of the Master Control Unit and the Machine Tool Receiver. Also included are 2X Vekttek Pressure Switches P/N 70-7500-78 and 2X M8 IP67 rated shielded switch to transmitter cables.



Figure 30: COMPONENT OVERVIEW

How to hook it up (wiring only):

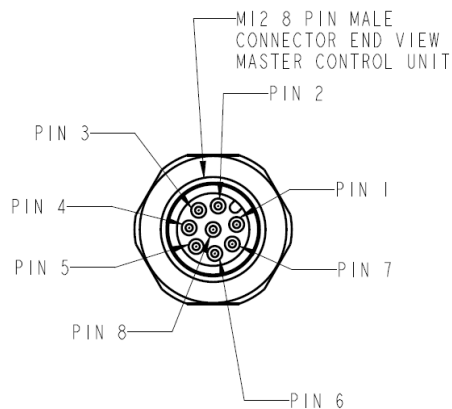

GUARDIAN MASTER CONTROL UNIT M12 8 PIN MALE CONNECTOR WIRING		
PIN NUMBER	STANDARD WIRE COLOR	FUNCTION
1	WHITE	0V
2	BROWN	+10-36 VDC
3	GREEN	CONDITION RELAY
4	YELLOW	RELAY COMMON
5	GRAY	N/A
6	PINK	N/A
7	BLUE	N/A
8	RED	N/A

Guardian Master Control Unit
P/N 33-0110-14
M12 8 Pin Male Connector Pinout

Figure 31: Guardian Simple interface wiring only

System Setup

Step 1: Once all items are installed and wired, plug in the Master Control Unit. It should power up automatically. The following screen should appear momentarily with information about the Master Control Unit.



Figure 32: Guardian Boot Screen

Step 2: No pairing is required for the Guardian System. Once a transmitter comes within range of the Machine Tool Receiver, communication will begin and the Fixture Transmitter will be identified and the condition of the Transmitter output by the Master Control Unit. The screen below will be the operational screen of the Guardian Simple.



Figure 33: Guardian Simple (33-0110-14) Main Screen

Step 3: Set up your pressure switch and Fixture Transmitter to open the pressure switch contacts and send a signal when it reaches the determined critical low pressure. NOTE: This MUST be done when the pressure is falling, pressure switch contact close at a different than they reopen. Different pressure switches have a different percent of their range as a “dead band” so it is CRITICAL to set this during a falling pressure condition.

Congratulations! You have just setup the VekteK Guardian™ system and are ready for operation.

Appendix A – Example Machine M-Code hookup schematic

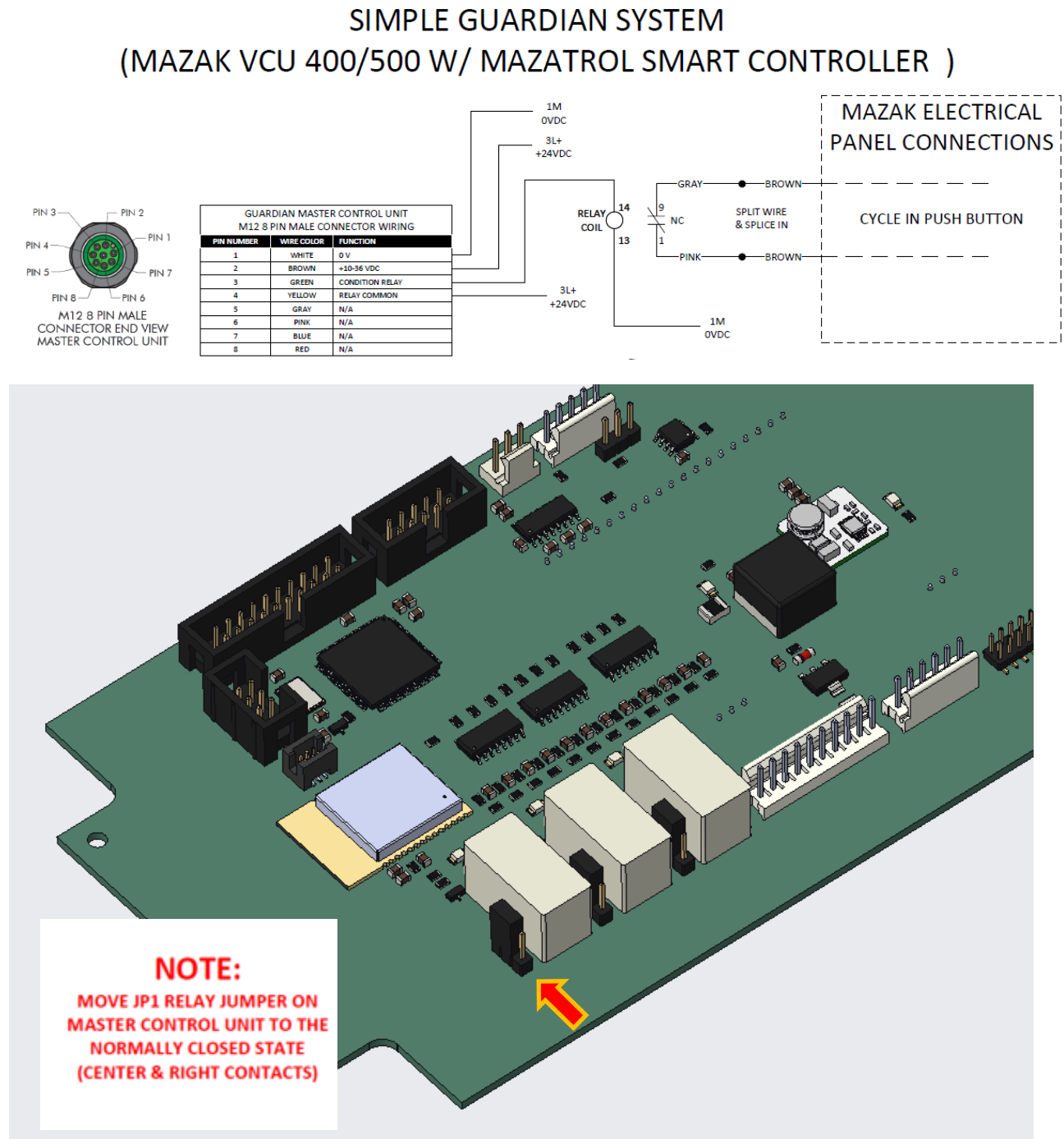
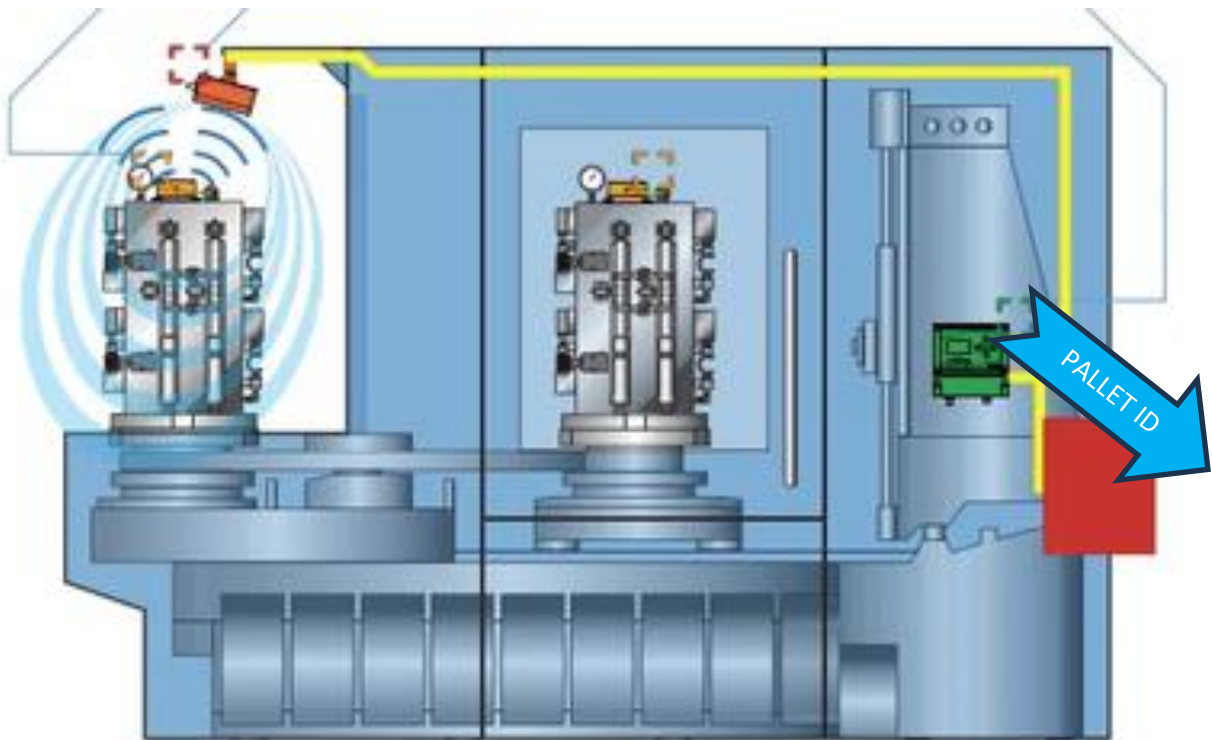

Figure 34: Wiring schematic for the Guardian Simple system that is integrated into the load stations cycle in push button

Guardian 1.0

Vektek's Machine Tool Protector



Contents

- 1.1 Overview
- 1.2 Software Settings
- 1.3 Electrical Connections
- 1.4 Communications

1.1 Overview

The Optional RS-232 Serial Interface provides an interface for the Guardian System to communicate to the machine controller, pallet handling system or automation controller to wireless identify which pallet is being read in the working area. The Guardian System reads through wireless technology all the Fixture Transmitter Units (FTU) in range and will use an internal algorithm to determine which reporting unit is closest to the Machine Tool Receiver (MTR) that has been mounted in the working area. Then depending on the users selection in Settings in the Master Control Unit (MCU), the FTU factory unique number will be sent over the serial communications port. Either based on time, operational state or via a serial command sent to the MCU from the Machine Controller. These modes of operation are detailed in section 1.2 of this Manual Supplement.

1.2 Software Settings

The Master Control Unit (MCU) determines the operation of the optional Serial Communications port feature. This is done through the system settings menu selections as described in this section.

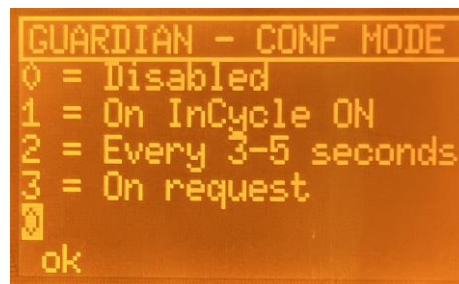

Figure 35: Pallet Serial

The output operation of the communications port is determined by settings under the system 'Settings Menu'. To enter the systems Setting Menu see section 'Guardian Simple System Menu Adjustments' on page 27 of this manual. Under this settings menu there is a section 'Pallet Serial' that determines the mode of operation. There are 4 possible modes of operation:

Mode 0 –

All Serial output and input monitoring is ignored.

Mode 1 –

Every time the MCU detects an FTU with good pressure, the unique serial number of the FTU is sent out the Serial Communications Port.

Mode 2 –

Every 3-5 seconds the MCU sends out the FTU that has been detected as the closest FTU to the MTR as defined by the internal algorithm. The message will be sent with no less than 3 seconds and no more than 5 seconds depending on other internal tasks to the MCU system with higher priorities.

Mode 3 –

When the MCU receives a message on the Receive pin of the communications port that matches the Request format, the MCU will reply with the FTU that has been detected as the closest FTU to the MTR as defined by the internal algorithm.

1.3 Electrical Connections

The connections for the optional Serial Communications port are thru the female M8 3 pin connector on the bottom of the MCU. The 3 pin connection are Transmit(TX), Receive(RX) and the Signal Common. The signal levels are industry standard RS-232 voltage levels. It is recommended that for cable connections that are longer than 3 meters or will be routed near devices that generate large EMI sources, to use shielded cables that are grounded at the Machine Controller end of the cable run.

PICO CONNECTOR WIRING
PICO PIN 3, GROUND
PICO PIN 4, TRANSMIT
PICO PIN 1, RECEIVE

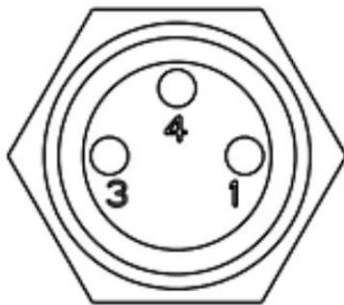
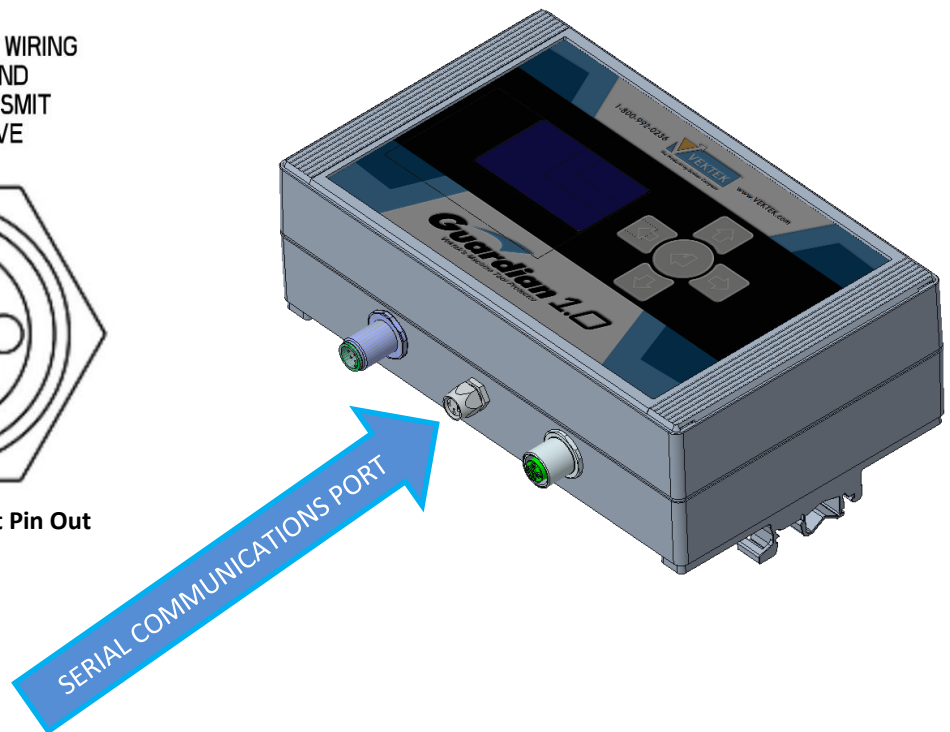

Figure 32: Serial Port Pin Out



1.4 Communications

The Protocol specifications for the optional Serial Communications port are as follows:

Baud Rate	Data bits	Parity Bit	Stop Bits
19,200	8	None	1

The message transmitted will be in the format of four digits followed by carriage return and linefeed.

For Example: 0048<CR><LF>

The unique FTU ID serial number has many more digits than are shown on the LCD screen of the MCU and is transmitted on the optional Serial Communications port. Only the 4 last digits are transmitted.

If there is no Pallet ID being read by the MTR/MCU("NO PALLET" condition) then the MCU sends four zeros '0000<CR><LF>' as described above when normal, based on the Mode selected in the MCU.

Serial Request of FTU Number

The MCU when set in Mode 3 will monitor the Serial Communications port looking for a single character to request data. When the 'R' (ASCII 82 decimal) character is detected on the receive port, the MCU will send the current FTU number in the format as described above.